











## ORIGINAL ARTICLE

# SORD-related peripheral neuropathy in a French and Swiss cohort: Clinical features, genetic analyses, and sorbitol dosages

Nicolas Pons<sup>1,2</sup>  | Gorka Fernández-Eulate<sup>3</sup> | Antoine Pegat<sup>4,5,6</sup>  | Marie Théaudin<sup>7</sup>  | Régis Guieu<sup>2</sup> | Paolo Ripellino<sup>8</sup>  | Manon Devedjian<sup>1</sup> | Patrick Mace<sup>2</sup> | Marion Masingue<sup>3</sup>  | Sarah Léonard-Louis<sup>3</sup> | Philippe Petiot<sup>4</sup> | Pauline Roche<sup>4</sup> | Emilien Bernard<sup>4,5,6</sup> | Françoise Bouhour<sup>4,6</sup> | Jean-Marc Good<sup>9</sup> | Annie Verschueren<sup>10</sup>  | Aude-Marie Grapperon<sup>10</sup>  | Emmanuelle Salort<sup>10</sup> | Anaïs Grosset<sup>11</sup> | Jean-Baptiste Chanson<sup>12</sup>  | Aleksandra Nadaj-Pakleza<sup>12</sup> | Anne-Laure Bédard-Millet<sup>13</sup> | Ariane Choumert<sup>14</sup>  | Anne Barnier<sup>15</sup> | Ghassen Hamdi<sup>15</sup> | Gaëtan Lesca<sup>16,17</sup> | Fabienne Prieur<sup>18</sup> | Arnaud Bruneel<sup>15</sup> | Philippe Latour<sup>6,19</sup> | Tanya Stojkovic<sup>3</sup> | Shahram Attarian<sup>10</sup> | Nathalie Bonello-Palot<sup>1,20</sup> 

<sup>1</sup>Département de Génétique Médicale, Hôpital Timone Enfants, Assistance Publique Hôpitaux de Marseille, Marseille, France

<sup>2</sup>Laboratory of Biochemistry, Timone Hospital, Marseille, France

<sup>3</sup>Nord/Est/Ile-de-France Neuromuscular Reference Centre, Pitié-Salpêtrière Hospital, Paris, France

<sup>4</sup>Service ENMG (ElectroNeuroMyoGraphie) et Pathologies Neuromusculaire, Hôpital Neurologique P. Wertheimer, Hospices Civils de Lyon, Lyon, France

<sup>5</sup>Centre SLA (Sclérose Latérale Amyotrophique) de Lyon, Hôpital Neurologique P. Wertheimer, Hospices Civils de Lyon, Université de Lyon, Bron, France

<sup>6</sup>Institut NeuroMyoGène, Université Lyon 1, CNRS UMR 5310, INSERM U1217, Lyon, France

<sup>7</sup>Department of Clinical Neurosciences, Service of Neurology, Lausanne University Hospital and University of Lausanne, Lausanne, Switzerland

<sup>8</sup>Neurology Department, Neurocentre of Southern Switzerland EOC, Lugano, Switzerland

<sup>9</sup>Division of Genetic Medicine, Lausanne University Hospital (CHUV) and University of Lausanne, Lausanne, Switzerland

<sup>10</sup>Referral Centre for Neuromuscular Diseases and ALS (Amyotrophic Lateral Sclerosis), Timone University Hospital, Marseille, France

<sup>11</sup>Referral Centre for Neuromuscular Diseases, Nancy University Hospital, Nancy, France

<sup>12</sup>Neurology Department, and Nord/Est/Ile de France Neuromuscular Reference Centre, Strasbourg University Hospital, Strasbourg, France

<sup>13</sup>Service of Neurophysiology, University Hospital Charles Nicolle of Rouen, Rouen, France

<sup>14</sup>Department of Rare Neurological Diseases, CHU de la Réunion, Saint-Pierre, France

<sup>15</sup>Metabolic and Cellular Biochemistry Department, AP-HP, Bichat Hospital, Paris, France

<sup>16</sup>Department of Genetics, University Hospitals of Lyon, Lyon, France

<sup>17</sup>Université Lyon, Université Lyon 1, CNRS, INSERM, Physiopathologie et Génétique du Neurone et du Muscle, UMR5261, U1315, Institut NeuroMyoGène, Lyon, France

<sup>18</sup>CHU de St. Etienne, Hôpital Nord, Service de Génétique Médicale, Saint-Etienne, France

<sup>19</sup>UF Pathologies Neurologiques Héritaires (UF 34427), Centre de Biologie et Pathologie Est, Service de Biochimie Biologie Moléculaire Grande Est, Hospices Civils de Lyon, Lyon, France

<sup>20</sup>Aix-Marseille University, Inserm, U1251-MMG, Marseille Medical Genetics, Marseille, France

## Correspondence

Nathalie Bonello-Palot, Département de Génétique Médicale, Hôpital Timone Enfants, Assistance Publique Hôpitaux de Marseille, Marseille, France.

Email: [nathalie.bonello@ap-hm.fr](mailto:nathalie.bonello@ap-hm.fr)

This is an open access article under the terms of the [Creative Commons Attribution-NonCommercial-NoDerivs](https://creativecommons.org/licenses/by-nc-nd/4.0/) License, which permits use and distribution in any medium, provided the original work is properly cited, the use is non-commercial and no modifications or adaptations are made.

© 2023 The Authors. *European Journal of Neurology* published by John Wiley & Sons Ltd on behalf of European Academy of Neurology.

## Abstract

**Background and purpose:** Biallelic variants in *SORD* have been reported as one of the main recessive causes for hereditary peripheral neuropathies such as Charcot–Marie–Tooth disease type 2 (CMT2) and distal hereditary motor neuropathy (dHMN) resulting in lower limb (LL) weakness and muscular atrophy. In this study, phenotype and genotype landscapes of *SORD*-related peripheral neuropathies were described in a French and Swiss cohort. Serum sorbitol dosages were used to classify *SORD* variants.

**Methods:** Patients followed at neuromuscular reference centres in France and Switzerland were ascertained. Sanger sequencing and next generation sequencing were performed to sequence *SORD*, and mass spectrometry was used to measure patients' serum sorbitol.

**Results:** Thirty patients had *SORD* peripheral neuropathy associating LL weakness with muscular atrophy, foot deformities (87%), and sometimes proximal LL weakness (20%) or distal upper limb weakness (50%). Eighteen had dHMN, nine had CMT2, and three had intermediate CMT. Most of them had a mild or moderate disease severity. Sixteen carried a homozygous c.757delG (p.Ala253Glnfs\*27) variant, and 11 carried compound heterozygous variants, among which four variants were not yet reported: c.403C>G, c.379G>A, c.68\_100+1dup, and c.850dup. Two unrelated patients with different origins carried a homozygous c.458C>A variant, and one patient carried a new homozygous c.786+5G>A variant. Mean serum sorbitol levels were 17.01 mg/L  $\pm$  8.9 SD for patients carrying *SORD* variants.

**Conclusions:** This *SORD*-inherited peripheral neuropathy cohort of 30 patients showed homogeneous clinical presentation and systematically elevated sorbitol levels (22-fold) compared to controls, with both diagnostic and potential therapeutic implications.

## KEYWORDS

Charcot–Marie–Tooth, muscular atrophy, neuropathy, peripheral neuropathy, *SORD*

## INTRODUCTION

Charcot–Marie–Tooth disease (CMT) and distal hereditary motor neuropathy (dHMN) are the most common types of hereditary peripheral neuropathies [1]. CMT is responsible for motor and sensory disabilities, usually affecting children and young adults. It can be secondary to either myelin (CMT1) or axonal (CMT2) damage and has an X-linked, recessive, or dominant inheritance [2]. Clinically, patients present with lower limb weakness and amyotrophy, foot deformities, and in some cases, sensory symptoms. In CMT2, there is predominant axonal injury responsible for a decrease in the compound muscle action potential, leading to muscle weakening and atrophy, as well as decreased sensory action potentials, which may or may not be clinically significant. The detection rate for causal variants is estimated at 36% for axonal CMT [3].

dHMN differs from CMT2 in that only the peripheral motor axons are damaged, leading to distal limb muscle weakness, sparing the sensory nerves. Inheritance is either autosomal recessive, dominant, or X-linked [4]. Common causative genes responsible for both dHMN and CMT2 such as *HSPB1*, *IHGMBP2*, and *GARS1* have

been described and therefore a phenotype overlap can be observed between these two forms of peripheral neuropathies [1, 5].

Both phenotypes have been associated with variants in the *SORD* gene as described by Cortese et al. in 2020 [6]. They identified 37 patients with the homozygous pathogenic variant c.757delG (p.Ala253Glnfs\*27) in exon 7 and eight patients with a compound heterozygous variant in *SORD*. The carrier frequency in healthy controls for the c.757delG variant is estimated at 0.0004 in GnomAD (v2.1.1; 115 alleles over 277,146) with one homozygous carrier reported (GnomAD v2.1.1). A total of 18 variants have been inventoried, summarized by Liu et al. [7], and one case described by Dong et al. [8] carried a compound heterozygous variant c.[404A>G;c.908+1G>C] without the c.757delG variant.

Recent studies [5, 8, 9, 10, 11] have further described the phenotype associated with *SORD* variants. The onset is generally around the second decade of life and is characterized with rather mild or moderate motor deficiency of the lower limbs.

In this observational descriptive study, 30 French and Swiss patients were clinically reported with peripheral neuropathies associated with homozygous and compound heterozygous pathogenic

variants in the *SORD* gene, and comparison of our findings with those reported in the literature was made. Furthermore, five novel pathogenic variants were identified and nonfasting serum sorbitol dosages were performed and helped in their classification as serum sorbitol is elevated when the variant is responsible for a *SORD* impairment, as reported by Cortese et al. [6].

## PATIENTS AND METHODS

### Design of the study cohort and biomolecular analysis of the *SORD* gene

The study cohort gathered patients from France and Switzerland. Clinical features were collected by French and Swiss neurologists; molecular diagnosis was established in Switzerland and in Lyon and Marseille, France. Data were collected from January 2021 to June 2022 and for some CMT patients undiagnosed at the molecular level, past medical records were consulted, some of them dating back to 1991.

Thus, the molecular analysis was achieved for 768 patients with CMT clinical presentation. DNA was obtained from peripheral blood (Biobank CRB Assistance Publique des Hôpitaux de Marseille, CRB TAC (Centre de Ressources Biologiques Tissus ADN Cellules) AP-HM, Marseille, France [BIORESOURCES]). Patients underwent either Sanger or next generation sequencing (NGS) panel sequencing.

Sanger sequencing was performed in a molecularly undiagnosed cohort analysed retrospectively presenting a CMT2 or a dHMN with an early onset of disease (before 50 years old) and a compatible recessive mode of inheritance or sporadic cases. For that, a nested polymerase chain reaction using the same primers as Cortese et al. [6] was designed.

NGS panel sequencing with genes related to CMT diseases was done both in a molecularly undiagnosed cohort of patients with *SORD* phenotype analysed retrospectively and in a cohort of patients with broader CMT2 symptoms analysed prospectively. To note, variants identified by NGS panels were confirmed with Sanger sequencing.

Patients with a *SORD* biallelic variant are referred to as *SORD*+/+ and control patients are referred as *SORD*wt/wt.

### *SORD*-mutated patients' enrolment and data collection

Patients were identified during national meetings of the FILNEMUS network (French Rare Neuromuscular Diseases Healthcare Network) gathering French molecular biology laboratories specializing in neuromuscular diseases with clinical neurology departments.

Disease severity was assessed using the validated CMT Neuropathy Score (CMTNS) or CMT Examination Score

(CMTES) [12]. Cases were classified as mild (CMTNS=0–10 or CMTES=0–7), moderate (CMTNS=11–20 or CMTES=8–16), or severe (CMTNS=21–36 or CMTES=17–28), according to their neurological examination.

All patients had electrodiagnostic studies by nerve conduction study and electromyography.

To note, Patient 18 in this cohort has already been described by Bernard et al. [13] (showing an unusual phenotype that could be classified as either juvenile amyotrophic lateral sclerosis or dHMN with pyramidal signs).

A pooled analysis comparing our findings with those of the literature (PubMed keywords used: *SORD*, neuropathy, peripheral neuropathy) was performed, with the clinical features collected.

Written and signed consent has been collected from the patients following French recommendations and in agreement with the local ethics committee rules. The study was ethically approved by the Aix-Marseille University Ethics Committee under the registered number PADS22-191.

### Sorbitol measurement in patients' serum with peripheral neuropathies

Nonfasting blood sorbitol was measured using high-performance liquid chromatography–tandem mass spectrometry (HPLC-MS/MS) in two French laboratories (Paris and Marseille). Sorbitol dosages were available for 55 patients: 22 patients with biallelic variants in *SORD*, 32 patients without *SORD* variants, identified as control patients (*SORD*wt/wt), and one unaffected heterozygote relative of Patient 27.

Paris's laboratory used Li et al.'s [14] method and Marseille's laboratory used a method derived from Li et al.'s based on an HPLC-MS/MS as well. The two methods were compared using 12 sera tested by the two laboratories: six from *SORD*+/+ patients and six from *SORD*wt/wt patients.

HPLC conditions of Marseille's laboratory were as follows: ACQUITY ethylene bridged hybrid column; amide, 1.7  $\mu$ m (2.1  $\times$  100 mm); eluent A, acetonitrile heated at 35°C; eluent B, 10 mM ammonium acetate; isocratic elution, 85% in A and 15% in B; flow rate, 0.6 mL/min. The retention time for sorbitol was 1.2 min. MS/MS conditions were as follows: H-ESI (Heated-Electronic spray ionization) interface in negative ion mode, 4200 V, ion transfer tube and vaporizer heated at 350°C. Multiple reaction monitoring transitions were 180.85/88.97 for sorbitol and 187.138/91.899 for internal standard.

For the sample preparation, serum and plasma samples were collected from patients in Marseille to make a comparison of the two matrices (performed on 11 *SORD*wt/wt patients and five *SORD*+/+ patients). Serum and plasma samples underwent protein precipitation with acetonitrile as follows: 50  $\mu$ L of plasma/serum were mixed with 150  $\mu$ L acetonitrile and 25  $\mu$ L of internal standard (D-SORBITOL U-13C6, 98%+; Cambridge Isotope Laboratories) diluted 1:10. Samples were centrifuged at 13,000 rpm for 10 min. Two hundred

microliters of supernatant was injected in the liquid chromatography. Neither laboratory used Oasis HLB cartridges as recommended by Cortese et al. Calibration curve (0.05–50mg/L) was done using standards prepared in water supplemented with internal standard in Marseille and in *SORD*wt/wt patients' serum supplemented with sorbitol in Paris. Internal quality controls were also prepared in water for each experiment.

## Statistical analysis

Clinical variables were reported as mean  $\pm$  SD and range for continuous variables and percentages for categorical ones. Continuous variables from sorbitol measurements were compared with a two-tailed Student t-test as specified in the figure legends. A *p*-value <0.05 was retained as significant.

## RESULTS

### Study cohort and number of CMT patients involved

Thirty patients with biallelic *SORD* variants were eventually retained for the clinical and sorbitol dosage evaluation; see flow chart in Figure 1.

### Identification of biallelic *SORD* variants in undiagnosed inherited neuropathies

Regarding patients with undiagnosed neuropathy analysed retrospectively, 9.4% of them ( $n=16/170$ ) eventually had biallelic *SORD* variants. For the patients analysed prospectively, 2.3% ( $n=14/598$ ) had biallelic variants in *SORD*. In total, we diagnosed *SORD* variants in 3.9% ( $n=30/768$ ) of patients of our cohort; 25 were diagnosed with

NGS panels and five with Sanger sequencing (see Figure 1). We have not experienced a false negative result in *SORD* analysis by panel that has secondarily been found positive by Sanger sequencing.

As a result, 30 patients were identified (P1–P30) from 29 different families with biallelic variants in the *SORD* gene (NM\_003104.6) including 27 French and three Swiss patients; 22 were sporadic cases and eight had family history of peripheral neuropathy (see data in Table S1). Of all the patients, 27 carried the deletion c.757delG; p.Ala253Glnfs\*27; chr15:45361217 (hg19, rs55901542), 16 in homozygous state and 11 were compound heterozygous. Two patients (P3 and P25) carried a homozygous c.458C>A (p.Ala153Asp), and one patient (P30) carried a new homozygous variant c.786+5G>A (p.?) altering the splicing. All those variants are shown in Figure 2 and were classified as pathogenic by Varsome [15] (see Table 1).

The familial inquiry was available for six index patients (P3, P6, P12, P19, P24, and P27), and the pedigree was available for 21 families (see Figure 3), consistent with the recessive mode of inheritance of *SORD*-associated peripheral neuropathy.

### Pooled analysis and phenotype of patients carrying biallelic variants in *SORD*

All clinical features of the 30 patients are summarized in Table 2 and in Table S2, comparing our results with those published earlier by Cortese et al. [6], Dong et al. [8], Laššuthová et al. [10], Liu et al. [7], and Frasquet et al. [9] (see also Table S1).

Twenty-one patients were from Europe (70%), eight from North Africa (26%), and one was from Reunion Island, Indian Ocean (4%). Of note, 73% ( $n=22/30$ ) of cases were sporadic without evidence of family history. The male/female sex ratio was equal to 2. Mean age at disease onset was  $12.36 \pm 5.99$  SD years old, and the mean age at examination was  $31.3 \pm 13.38$  SD years old.

The clinical diagnosis was dHMN in 18 patients (60%), axonal CMT (CMT2) in nine patients (30%), and intermediate CMT in three patients (10%). All patients had distal lower limb weakness, and six (20%) also had associated proximal lower limb weakness. For 43% ( $n=13/30$ ) of patients, the posterior compartment of the leg was affected; four patients (P1, P5, P6, P28) had the triceps surae more affected than the tibialis anterior, nine patients had both the triceps surae and the tibialis anterior affected similarly (P13, P14, P17, P18, P19, P22, P26, P27, P30), and seven patients had the tibialis anterior mostly affected (P4, P7, P8, P10, P12, P23, P24). Twenty-eight patients (93%) had concomitant distal lower limb amyotrophy. Twenty-six patients (87%) presented pes cavus or other foot deformities such as hammer toes.

Disease-related symptom severity was classified as mild according to the CMTNS and CMTEs scores in 25 of 30 patients (83%) and moderate in 5 of 30 (17%).

Patients with the homozygous c.757delG variant were the only ones to have scoliosis (four patients among the 16 with homozygous c.757delG: P7, P21, P24, P26) and reduced pinprick superficial sensation of the lower limbs (three patients among the 16 with

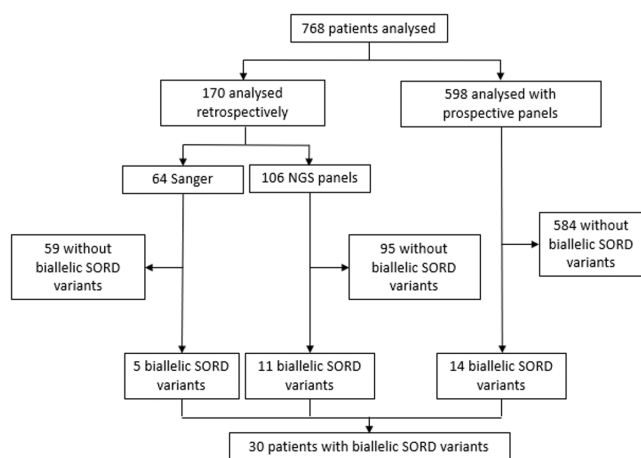

**FIGURE 1** Flow chart diagram representing our cohort of interest. In total, 30 patients had biallelic *SORD* variants and were included in our study. NGS, next generation sequencing.

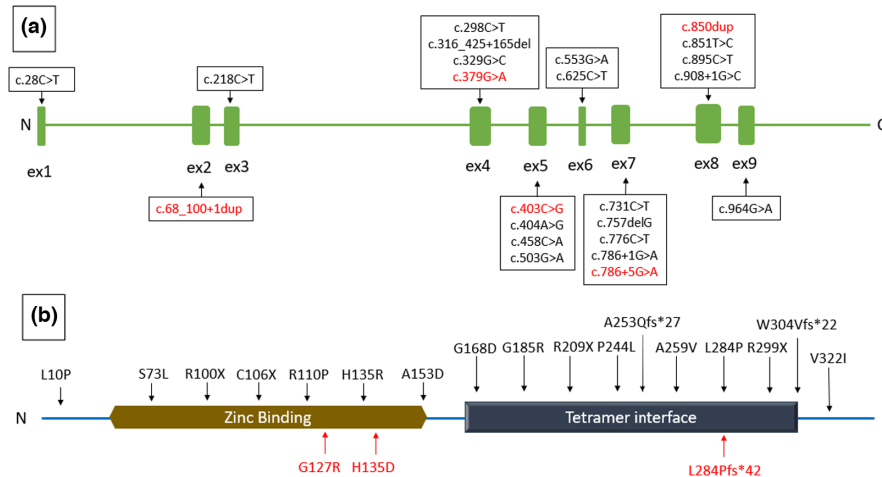

**FIGURE 2** Representation of the *SORD* gene and the sorbitol dehydrogenase enzyme. (a) Positions of all the *SORD* variants identified in the literature. Five individuals (probands of Families 1, 14, 23, 28, and 29) carried the c.757delG(p.A253Qfs\*27) variant, with a second unreported variant including c.379G>A (p.G127R) for Families 14 and 23, c.403C>G(p.H135D) for Family 1, c.68\_100+1dup (p.?) for Family 28, and c.850dup for Family 29 (p.L284Pfs\*42), and the proband of Family 30 carried a homozygous c.786+5G>A(p.?). All new variants are marked in red. (b) Variant localizations in the protein.

homozygous c.757delG: P17, P19, P22), and they mainly presented dHMN (12 patients among the 16 with homozygous c.757delG) rather than CMT2 or intermediate CMT.

P3 and P25 with homozygous c.458C>A (p.Ala153Asp) and P30 with the homozygous c.786+5G>A did not show a different phenotype than those either carrying homozygous c.757delG or compound heterozygous with c.757delG.

On nerve conduction studies, 67% ( $n=20/30$ ) of the patients had a motor phenotype and 33% ( $n=10/30$ ) both motor and sensory phenotype. Only three patients had reduced motor nerve conduction velocity of the median nerve.

## Patients' sorbitol blood levels

Regarding the correlation between plasma and serum sorbitol levels, there were no statistically significant differences between the two matrices regarding control ( $p=0.62$ ) and *SORD*+/+ patients ( $p=0.82$ ), suggesting the analysis can be performed on both (see Figure 4c,d).

Regarding the correlation between the two dosing laboratories, there were no statistically significant differences for both control ( $p=0.16$ ) and *SORD*+/+ patients ( $p=0.80$ ) as shown in Figure S1. The control patients did not show increased sorbitol level in any laboratories, and *SORD*+/+ patients had increased sorbitol levels in Paris and Marseille in the same range of values.

Twenty-two *SORD*+/+ patients had a mean increased serum sorbitol level of  $17.01\text{mg/L} \pm 8.9\text{SD}$ . Among them, 11 patients carrying the homozygous c.757delG variant had mean serum sorbitol levels of  $17.2\text{mg/L} \pm 4.24\text{SD}$  and 10 patients carrying compound heterozygous variants in *SORD* had mean serum sorbitol levels of  $17.3\text{mg/L} \pm 12.7\text{SD}$ ; the slight difference between both groups was not significant ( $p=0.74$ ; see Figure 4). One patient carrying

homozygous c.458C>A had a sorbitol level of 11.35 mg/L. Of note, P16 with c.[458C>A;757delG] had the highest sorbitol level at 51.9 mg/L and had an early onset of disease at 8 years old. He was the only patient of the cohort to have reduced pinprick superficial sensation in the upper limbs without any muscular atrophy, and all deep tendon reflexes were present (as they also were for P2, P7, P9, P18). He presented a mild CMT2.

For the 32 control patients, the mean sorbitol level was  $0.79 \pm 0.52$  (range=0.27–2.17) mg/L. The unaffected heterozygote member of Family 27 carrying only the c.553G>A Het (p.Gly185Arg) variant also had normal sorbitol levels (1.13 mg/L) in accordance with the autosomal recessive inheritance of *SORD*.

Serum sorbitol levels of patients with biallelic *SORD* variants were 22-fold higher than controls ( $p<0.0001$ ). No *SORD*+/+ patients had a normal serum sorbitol level.

Regarding the time from onset of the disease to sampling, three groups of patients were analysed (5–10 years, 10–15 years, and >15 years). There was no statistically significant difference in sorbitol levels between the different groups (see Figure S1c).

## DISCUSSION

In this study, 30 patients from France and Switzerland with peripheral hereditary neuropathies related to the *SORD* gene were reported.

Regarding the molecular diagnosis, five new variants were discovered: c.403C>G, c.379G>A, c.68\_100+1dup, c.850dup together with c.757delG, and a homozygous c.786+5G>A variant that has not been reported in the literature and has never been identified in GnomAD [17] (v2.1.1). The patients' phenotype with those new variants was not different from the rest of the cohort carrying other variants.

**TABLE 1** Table summarizing all the variants identified in this study.

Variants identified	Patients with this variant	GnomAD (v2.1.1) frequencies	Pathogenicity score <sup>a</sup>	Sorbitol dosages
c.68_100 + 1dup (p:?) <sup>b</sup>	1 heterozygous	No GnomAD genome entry	Pathogenic	16.6 mg/L when associated with c.757delG
c.298C > T (p.-Arg100*) <sup>c</sup>	1 heterozygous	0.007%	Pathogenic	12.4 mg/L when associated with c.757delG
c.329G > C (p.-Arg110Pro) <sup>c</sup>	1 heterozygous	No GnomAD genome entry but has been described by Cortese et al.	Pathogenic	10.4 mg/L when associated with c.757delG
c.379G > A (p.Gly127Arg) <sup>b</sup>	2 heterozygous	No GnomAD genome entry	Pathogenic	10 mg/L when associated with c.757delG (1 more patient not available for dosage)
c.403C > G (p.-His135Asp) <sup>b</sup>	1 heterozygous	No GnomAD genome entry	Pathogenic	11 mg/L when associated with c.757delG
c.458C > A (p.-Ala153Asp) <sup>c</sup>	3 heterozygous 2 homozygous	0.04%	Pathogenic	When associated with c.757delG: 3 different dosages of 21.1 mg/L, 12.7 mg/L, and 51.9 mg/L When associated with another c.458C > A: 11.35 mg/L (1 more patient not available for dosage)
c.553G > A (p.Gly185Arg) <sup>c</sup>	1 heterozygous	0.00003%	Pathogenic	17.34 mg/L when associated with c.757delG
c.757delG (p.-Ala253Glnfs*27) <sup>c</sup>	16 homozygous	0.0004%	Pathogenic	Mean $\pm$ SD of 17.22 $\pm$ 4.24 mg/L (based on the dosage of 11 patients)
c.786 + 5G > A (p:?) <sup>b</sup>	1 homozygous	No GnomAD genome entry	Pathogenic	Not available
c.850dup (p.-Leu284Profs*42) <sup>b</sup>	1 heterozygous	No GnomAD genome entry	Pathogenic	9.99 mg/L when associated with c.757delG

<sup>a</sup>Pathogenicity score according to American College of Medical Genetics and Genomics [16].<sup>b</sup>Variant discovered in this study and never described in the literature.<sup>c</sup>Variant already described in the literature.

**FIGURE 3** Pedigrees and genotypes of 21 families in our study with *SORD* variants. Squares represent males, circles females, and diamonds unspecified gender. Arrows represent index patients. Squares or circles crossed by a diagonal line are used for deceased individuals. Patients are represented with filled black shapes. Individuals with gray shapes show incomplete phenotype. The number inside the shapes represents the number of individuals. wt, wild type.

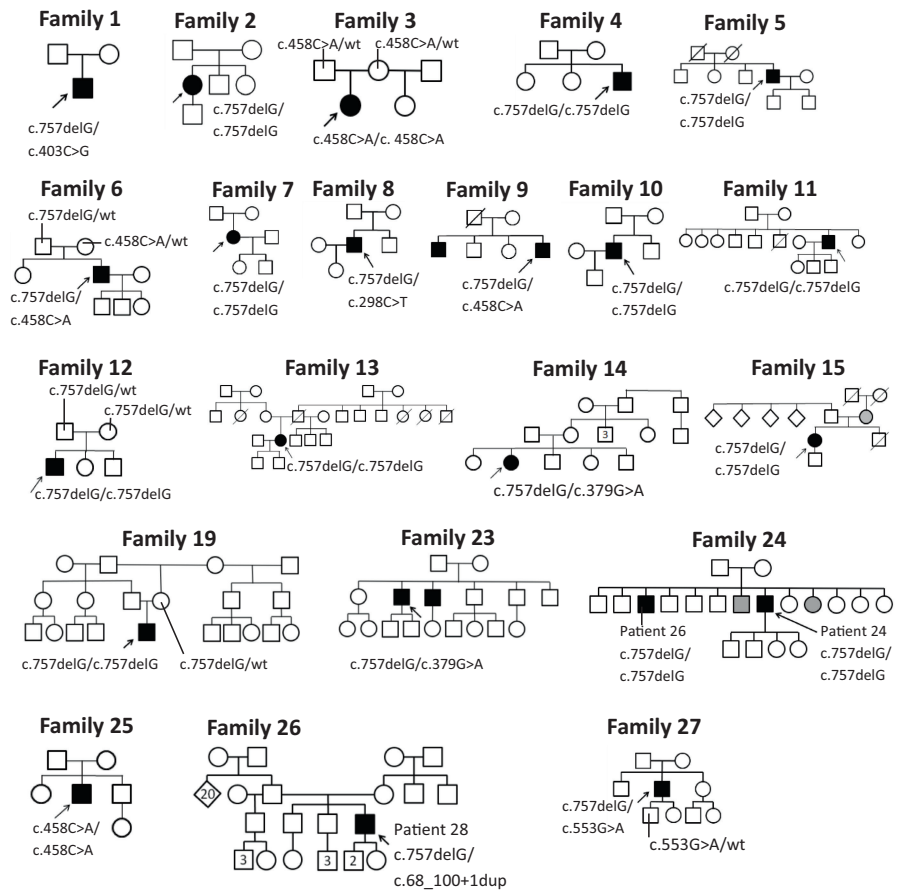

The age at onset of the disease was early in our cohort and was approximately 12 years old, whereas it can be much higher in the CMT field [18]. Our results are consistent with those already described in the literature, although dHMN phenotypes were more frequent in our cohort than in previously reported ones; 60% had dHMN, compared to 40% and 11%, respectively, in Cortese et al. and Laššuthová et al.'s studies; 30% had a CMT2, compared to 51% and 77%, respectively, in Cortese et al. and Laššuthová et al.'s studies; and 10% had an intermediate CMT, compared to 9% in Cortese et al. and 11% in Laššuthová et al.'s studies. It is important to mention that the posterior compartment of the lower legs seemed to be frequently involved and in four patients it was even more important than the anterior one. We also confirmed that *SORD*-associated peripheral neuropathies are generally mild or moderate in severity, as 83% of patients had a mild neuropathy and 17% had a moderate one, consistent with Cortese et al.'s study showing mainly mild neuropathies in 67% of patients, whereas 31% had moderate forms.

Regarding the serum sorbitol levels, *SORD*wt/wt patients had mean  $0.79 \pm 0.52$  (range = 0.27–2.17) mg/L. We found different sorbitol normal values in the literature. Grosz et al. [19] measured the plasma sorbitol level of one control patient, which was 0.2 mg/L, consistent with the  $0.164 \pm 0.044$  mg/L published by Preston and Calle [20] (13 healthy control patients) and the  $0.2 \pm 0.068$  mg/L reported by Shetty et al. [21] (12 patients measured).

Li et al [14]. published that the basal sorbitol level should be 0.72–1.46  $\mu$ M, which is approximately equivalent to 0.13–0.27 mg/L, knowing that sorbitol's molar mass is 182.17 g/mol. Cortese et al [6]. derived their dosing method from Li et al.'s but found a basal sorbitol level of  $0.046 \pm 0.004$  mg/L (10 control patients), which is 3–6 times lower. The Human Metabolome Database reported various normal blood values:  $<2198 \mu$ M, equivalent to  $<0.4$  mg/L, in a series of 33 patients published by Vanholder et al. [22] and another normal value of 13 (range = 4–24)  $\mu$ M, equivalent to 2.4 (0.7–4.4) mg/L.

Finally, Hwang et al [23]. reported plasma sorbitol level of 0.02 mmol/L in 25 pregnant women, equivalent to 3.6 mg/L. As a result, our findings were spread between the lowest and the highest sorbitol normal values found in the literature. The differences may be due to different extraction methods; for instance, the Oasis cartridges recommended by Cortese et al. were not used in this study.

*SORD*+/+ patients had sorbitol values of  $17.01 \text{ mg/L} \pm 8.9 \text{ SD}$  (range = 9.99–51.9) compared to the  $14.82 \text{ mg/L} \pm 0.780 \text{ SD}$  of Cortese et al. [6]. The lowest value was 9.99 mg/L, which is still almost 5 times higher than the highest normal sorbitol level of 2.17 mg/L. The personal history of diabetes was available for 23 patients, 18 of whom had a sorbitol dosage performed, and none was diabetic, suggesting the increased sorbitol levels were not due to diabetes.

**TABLE 2** Clinical features of patients with peripheral neuropathies associated with biallelic *SORD* variants in our cohort,  $N=30$ .

Feature	n (%)
Sex, male	21/30 (70%)
Family history	7/30 (23%)
Age at onset, years, mean $\pm$ SD	12.36 $\pm$ 5.99
Normal psychomotor development	16/30 (53%)
Age at examination, years, mean $\pm$ SD (min-max)	31.3 $\pm$ 13.38 (8-64)
Neuropathy subtype	
CMT2	9/30 (30%)
dHMN	18/30 (60%)
CMT intermediate	3/30 (10%)
Pes cavus	26/30 (87%)
Abnormal walking	27/30 (90%)
Tiptoe impossible	22/30 (73%)
Walking on heels impossible	27/30 (90%)
Scoliosis	4/30 (13%)
Upper limb weakness	
Proximal muscle groups	0/30
Distal muscle groups	15/30 (50%)
Lower limb weakness	
Proximal muscle groups	6/30 (20%)
Distal muscle groups	30/30 (100%)
Axial weakness	1/30 (3%)
Facial weakness	0/30
Limb tremor	7/30 (23%)
Muscular atrophy	
Proximal upper limbs	0/30
Distal upper limbs	11/30 (37%)
Proximal lower limbs	2/30 (7%)
Distal lower limbs	28/30 (93%)
Absence of deep tendon reflexes	
Achilles	24/30 (80%)
Patellar	8/30 (27%)
Upper limbs	2/30 (7%)
Reduced vibratory sensation	
Lower limbs	13/30 (43%)
Upper limbs	0/30
Reduced pinprick superficial sensation	
Upper limbs	1/30 (3%)
Lower limbs	3/30 (10%)
Respiratory insufficiency	0/30
Diabetes	0/23
Overweight	5/23 (22%)
Disease severity per CMTNS	
Mild	25/30 (83%)

**TABLE 2** (Continued)

Feature	n (%)
Moderate	5/30 (17%)
Severe	0/30
Ankle-foot orthoses or other walking aids	16/30 (53%)
Nerve conduction studies	
Abnormal motor nerves	20/30 (67%) <sup>a</sup>
Abnormal sensory + motor nerves	10/30 (33%)

Abbreviations: CMT, Charcot-Marie-Tooth disease; CMTNS, CMT Neuropathy Score; dHMN, distal hereditary motor neuropathy; min-max, minimum-maximum.

<sup>a</sup>3/28 (11%) with reduced motor conduction velocity.

Furthermore, the result of this potential biomarker must be correlated to the identification of biallelic *SORD* variants before making the diagnosis. Biomarkers play an interesting role in medicine, as their follow-up can be achieved when a clinical trial is launched to monitor the efficacy of a treatment. For instance, deoxysphingolipids have shown their usefulness in HSAN (Hereditary Sensory and Autonomic Neuropathies) [24].

Patient 16 had the highest sorbitol level ever reported in the literature. His diagnosis was established at 8 years old, which is earlier than the diagnostic age of the cohort (mean = 32  $\pm$  13.7 SD years old), and he was 56 years old when the sorbitol sampling was done. We hypothesized that the sorbitol level was increasing along the course of the disease, but the comparison over time of sorbitol levels between the different groups showed no significant differences between various individuals, suggesting sorbitol level remains stable; however, this should be assessed by a prospective study evaluating sorbitol levels at different times within the same patient.

Laššuthová et al. [10] recommended the use of more specific primers they designed to prevent the sequencing of the pseudogene *SORD2P* and therefore a false positive diagnosis. The primers used in our study were similar to those designed by Cortese et al. Nevertheless, in all 22 patients identified with biallelic *SORD* variants, sorbitol levels were pathologically increased. If our primers were to amplify and find a variant in the pseudogene *SORDP2* instead of *SORD*, it should not have enzymatic consequences and sorbitol levels should not be altered by an *SORDP2* impairment. They also suggest the use of the primers designed by Cortese et al. may result in an allele dropout as it lacks specificity to *SORD* and might hybridize with *SORDP2*. However, in our study, we were able to identify 11 compound heterozygous patients with increased sorbitol levels, suggesting the two variants identified belonged to the two *SORD* alleles. Furthermore, P27 carrying c.[553G>A;757delG] transmitted to his son only the c.553G>A variant and P6 with c.[458C>A;757delG] inherited the c.757delG variant from his father and the c.458C>A variant from his mother, proving variants were in trans in P27 and P6.

The polyol pathway transforms glucose into fructose in two steps; first, glucose is metabolized into sorbitol by the aldose



**FIGURE 4** Sorbitol levels (mg/L) measured by high-performance liquid chromatography. (a) Sorbitol levels of patients carrying biallelic variants in *SORD* compared to controls. (b) Comparison of sorbitol levels between patients carrying a homozygous variant c.757delG and patients carrying compound heterozygous variants together with c.757delG. (c) Comparison of serum and plasma sorbitol levels in control patients. (d) Comparison of serum and plasma sorbitol levels in patients with biallelic mutations in *SORD*. The graphs show the mean  $\pm$  SD and data distribution (dots) and the *p*-value of two-tailed *t*-tests comparing sorbitol levels across groups (\*\*\*\**p* < 0.0001). CTRL, control; Het, heterozygous; Hom, homozygous; ns, nonsignificant; wt, wild type.

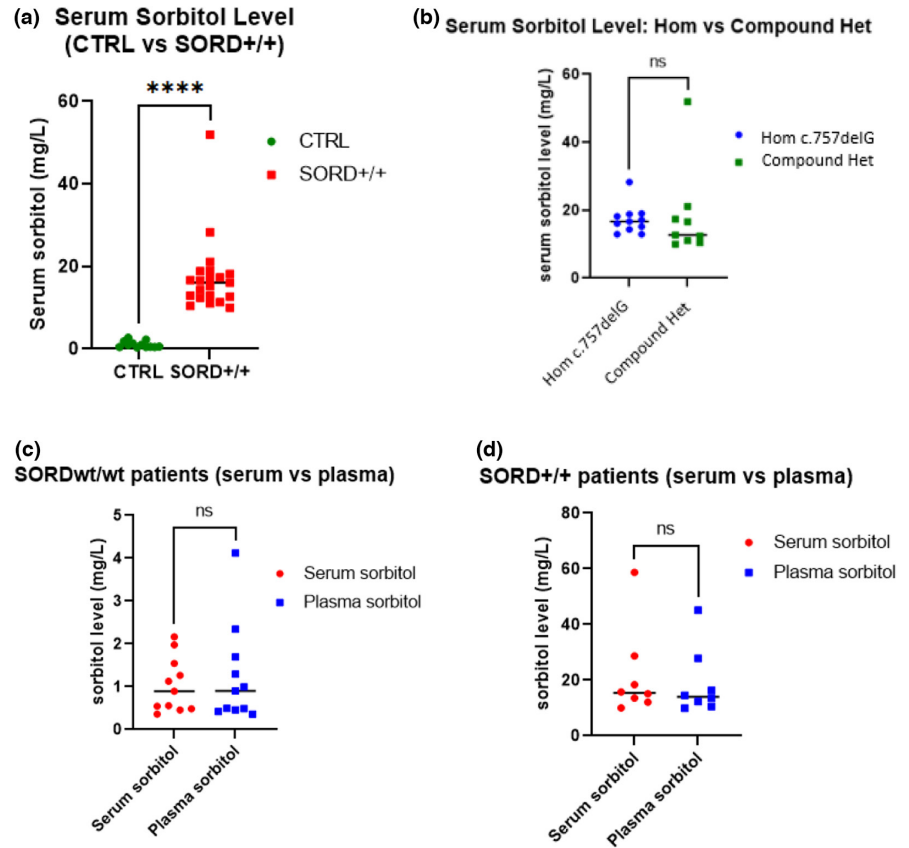

reductase and second, sorbitol is transformed into fructose by the sorbitol dehydrogenase. The aldose reductase inhibitors (ARIs) lead to a decrease in sorbitol. Oyama et al. [24] explained that sorbitol accumulation in human umbilical vein endothelial cells results in increased osmotic pressure and oxidative stress, leading to cell injury such as microvascular endothelial damage observed in diabetic neuropathy. Ranirestat, an ARI, was reported by Sekiguchi et al. [26] to decrease the erythrocyte sorbitol concentration (closely related to the nerve sorbitol content [27]) by 75.82% versus a placebo group of diabetic patients. They also demonstrated that ranirestat was responsible for an increase of 0.52 m/s in nerve conduction velocity after 1 year of treatment, counterbalancing the annual decrease of 0.5 m/s mentioned by Hotta et al. [28]. According to the studies conducted by Hotta et al. [28, 29] and Brill and Buchanan [30], the use of fidarestat, epalrestat, and ranirestat improved diabetic patient-reported neuropathy symptomatology and nerve conduction velocity. However, ARI may have limited impact, as when the neuropathy is settled, the damage might be irreversible, because peripheral nerves affected are not readily regenerated [31]. Thus, the treatment should be delivered as soon as possible after disease onset, and neurologists should be aware of the clinical phenotype and perform a sorbitol and/or a molecular analysis.

## CONCLUSIONS

This study identifies a new European cohort of 30 patients carrying variants in the *SORD* gene. Five new variants were

described, c.403C>G (p.His135Asp), c.379G>A (p.Gly127Arg), c.68\_100+1dup, c.850dup, and c.786+5G>A, and the first three cases with homozygous c.458C>A (p.Ala153Asp) and homozygous c.786+5G>A were reported.

The serum sorbitol dosage is a functional test demonstrating the impairment of sorbitol dehydrogenase. This dosage has three purposes. First, it allows geneticists to classify variants as pathogenic when sorbitol levels are increased. Second, it could be a first screening test achieved faster than the molecular one. Third, it could be envisaged as a biomarker to monitor a therapeutic trial.

This study could be the starting point for a new clinical trial using aldose reductase inhibitors for these 30 patients.

## AUTHOR CONTRIBUTIONS

Nicolas Pons, Nathalie Bonello-Palot, Shahram Attarian, and Régis Guieu contributed to the design of the study. Nathalie Bonello-Palot contributed to supervision and mentorship. Nicolas Pons, Patrick Mace, Nathalie Bonello-Palot, Gorka Fernández-Eulate, Arnaud Bruneel, Anne Barnier, Ghassen Hamdi, and Manon Devedjian participated in data analysis and interpretation. Nicolas Pons, Nathalie Bonello-Palot, Gorka Fernández-Eulate, Arnaud Bruneel, and Marie Théaudin contributed to manuscript drafting. Gorka Fernández-Eulate, Antoine Pegat, Marie Théaudin, Jean-Marc Good, Paolo Ripellino, Annie Verschueren, Anaïs Grosset, Aude-Marie Grapperon, Emmanuelle Salort, Fabienne Prieur, Jean-Baptiste Chanson, Anne-Laure Bédard-Millet, Ariane Choumert, Aleksandra Nadaj-Pakleza, Tanya Stojkovic, Gaëtan Lesca, Pauline Roche, Philippe Petiot, Emilien ard, and Françoise Bouhour contributed to the collection of clinical

data during consultations. All authors participated in critical revisions of the manuscript and take responsibility for its integrity and the accuracy of the data analysis.

## ACKNOWLEDGMENTS

The authors would like to thank the patients and their families for their cooperation.

## FUNDING INFORMATION

No specific grant for this research from any funding agency in the public, commercial, or not-for-profit sectors has been received by the authors.

## CONFLICT OF INTEREST STATEMENT

The authors state explicitly that there are no conflicts of interest in connection with this article.

## DATA AVAILABILITY STATEMENT

The data that support the findings of this study are available from the corresponding author upon reasonable request.

## ORCID

Nicolas Pons  <https://orcid.org/0000-0003-1691-3915>

Antoine Pegat  <https://orcid.org/0000-0003-1563-9432>

Marie Théaudin  <https://orcid.org/0000-0002-3026-3595>

Paolo Ripellino  <https://orcid.org/0000-0002-8662-9656>

Marion Masingue  <https://orcid.org/0000-0002-4898-709X>

Annie Verschueren  <https://orcid.org/0000-0003-1266-9062>

Aude-Marie Grapperon  <https://orcid.org/0000-0002-4196-9374>

Jean-Baptiste Chanson  <https://orcid.org/0000-0003-4221-3840>

Ariane Choumert  <https://orcid.org/0000-0001-6476-362X>

Nathalie Bonello-Palot  <https://orcid.org/0000-0002-8657-1271>

## REFERENCES

- Benquey T, Pion E, Cossée M, et al. A National French Consensus on gene list for the diagnosis of Charcot-Marie-tooth disease and related disorders using next-generation sequencing. *Genes*. 2022;13(2):318.
- Morena J, Gupta A, Hoyle JC. Charcot-Marie-tooth: from molecules to therapy. *Int J Mol Sci*. 2019;20(14):3419.
- Bacquet J, Stojkovic T, Boyer A, et al. Molecular diagnosis of inherited peripheral neuropathies by targeted next-generation sequencing: molecular spectrum delineation. *BMJ Open*. 2018;8(10):e021632.
- Rossor AM, Kalmar B, Greensmith L, Reilly MM. The distal hereditary motor neuropathies. *J Neurol Neurosurg Psychiatry*. 2012;83(1):6-14.
- Xie Y, Lin Z, Pakhrin PS, et al. Genetic and clinical features in 24 Chinese distal hereditary motor neuropathy families. *Front Neurol*. 2020;11:603003.
- Cortese A, Zhu Y, Rebelo A, et al. Biallelic mutations in SORD cause a common and potentially treatable hereditary neuropathy with implications for diabetes. *Nat Genet Mai*. 2020;52(5):473-481.
- Liu X, He J, Yilihamu M, Duan X, Fan D. Clinical and genetic features of biallelic mutations in SORD in a series of Chinese patients with Charcot-Marie-tooth and distal hereditary motor neuropathy. *Front Neurol*. 2021;12:733926.
- Dong HL, Li JQ, Liu GL, Yu H, Wu ZY. Biallelic SORD pathogenic variants cause Chinese patients with distal hereditary motor neuropathy. *NPJ Genomic Med*. 2021;6:1.
- Frasquet M, Rojas-García R, Argente-Escrig H, et al. Distal hereditary motor neuropathies: mutation spectrum and genotype-phenotype correlation. *Eur J Neurol*. 2021;28(4):1334-1343.
- Laššuthová P, Mazanec R, Staněk D, et al. Biallelic variants in the SORD gene are one of the most common causes of hereditary neuropathy among Czech patients. *Sci Rep*. 2021;11:8443.
- Yuan R, Ye Z, Zhang X, Xu L, He J. Evaluation of SORD mutations as a novel cause of Charcot-Marie-tooth disease. *Ann Clin Transl Neurol*. 2020;8(1):266-270.
- Murphy SM, Herrmann DN, McDermott MP, et al. Reliability of the CMT neuropathy score (second version) in Charcot-Marie-tooth disease. *J Peripher Nerv Syst*. 2011;16(3):191-198.
- Bernard E, Pegat A, Vallet AE, et al. Juvenile amyotrophic lateral sclerosis associated with biallelic c.757delG mutation of sorbitol dehydrogenase gene. *Amyotroph Lateral Scler Front Degener*. 2022;23(5-6):473-475.
- Li F, Cousineau C, Xing G, et al. Development and validation of a quantitative ultra performance LC® hydrophilic interaction liquid chromatography MS/MS method to measure fructose and sorbitol in human plasma. *Bioanalysis*. 2019;11(5):407-425.
- Kopanos C, Tsiolkas V, Kouris A, et al. VarSome: the human genomic variant search engine. *Bioinformatics*. 2019;35(11):1978-1980.
- Richards S, Aziz N, Bale S, et al. Standards and guidelines for the interpretation of sequence variants: a joint consensus recommendation of the American College of Medical Genetics and Genomics and the Association for Molecular Pathology. *Genet Med*. 2015;17(5):405-424. <https://doi.org/10.1038/gim.2015.30>
- Lek M, Karczewski KJ, Minikel EV, et al. Analysis of protein-coding genetic variation in 60,706 humans. *Nature*. 2016;536(7616):285-291.
- Subréville M, Bonello-Palot N, Yahiaoui D, et al. Genotype-phenotype correlation in French patients with myelin protein zero gene-related inherited neuropathy. *Eur J Neurol*. 2021;28(9):2913-2921.
- Grosz BR, Stevanovski I, Negri S, et al. Long read sequencing overcomes challenges in the diagnosis of SORD neuropathy. *J Peripher Nerv Syst*. 2022;27(2):120-126.
- Preston GM, Calle RA. Elevated serum sorbitol and not fructose in type 2 diabetic patients. *Biomark Insights*. 2010;5:33-38.
- Shetty HU, Holloway HW, Rapoport SI. Capillary gas chromatography combined with ion trap detection for quantitative profiling of polyols in cerebrospinal fluid and plasma. *Anal Biochem*. 1995;224(1):279-285.
- Vanholder R, Smet RD, Glorieux G, et al. Review on uremic toxins: classification, concentration, and interindividual variability. *Kidney Int*. 2003;63(5):1934-1943.
- Hwang JJ, Johnson A, Cline G, et al. Fructose levels are markedly elevated in cerebrospinal fluid compared to plasma in pregnant women. *PLoS ONE*. 2015;10(6):e0128582.
- Boso F, Armirotti A, Taioli F, et al. Deoxysphingolipids as candidate biomarkers for a novel SPTLC1 mutation associated with HSN-I. *Neurol Genet*. 2019;5(6):e365.
- Oyama T, Miyasita Y, Watanabe H, Shirai K. The role of polyol pathway in high glucose-induced endothelial cell damages. *Diabetes Res Clin Pract*. 2006;73(3):227-234.
- Sekiguchi K, Kohara N, Baba M, et al. Aldose reductase inhibitor ranirestat significantly improves nerve conduction velocity in diabetic polyneuropathy: a randomized double-blind placebo-controlled study in Japan. *J Diabetes Investig*. 2019;10(2):466-474.

27. Schemmel KE, Padiyara RS, D'Souza JJ. Aldose reductase inhibitors in the treatment of diabetic peripheral neuropathy: a review. *J Diabetes Complications*. 2010;24(5):354-360.
28. Hotta N, Toyota T, Matsuoka K, et al. Clinical efficacy of Fidaestat, a novel aldose reductase inhibitor, for diabetic peripheral neuropathy. *Diabetes Care*. 2001;24(10):1776-1782.
29. Hotta N, Akanuma Y, Kawamori R, et al. Long-term clinical effects of Epalrestat, an aldose reductase inhibitor, on diabetic peripheral neuropathy: the 3-year, multicenter, comparative aldose reductase inhibitor-diabetes complications trial. *Diabetes Care*. 2006;29(7):1538-1544.
30. Bril V, Buchanan RA, the AS-3201 Study Group. Aldose reductase inhibition by AS-3201 in sural nerve from patients with diabetic sensorimotor polyneuropathy. *Diabetes Care*. 2004;27(10):2369-2375.
31. Giannoukakis N. Ranirestat as a therapeutic aldose reductase inhibitor for diabetic complications. *Expert Opin Investig Drugs*. 2008;17(4):575-581.

## SUPPORTING INFORMATION

Additional supporting information can be found online in the Supporting Information section at the end of this article.

**How to cite this article:** Pons N, Fernández-Eulate G, Pegat A, et al. SORD-related peripheral neuropathy in a French and Swiss cohort: Clinical features, genetic analyses, and sorbitol dosages. *Eur J Neurol*. 2023;00:1-11. doi:[10.1111/ene.15793](https://doi.org/10.1111/ene.15793)